

VERTICLE (WALL MOUNTED) SPIN FILTER ASSEMBLIES

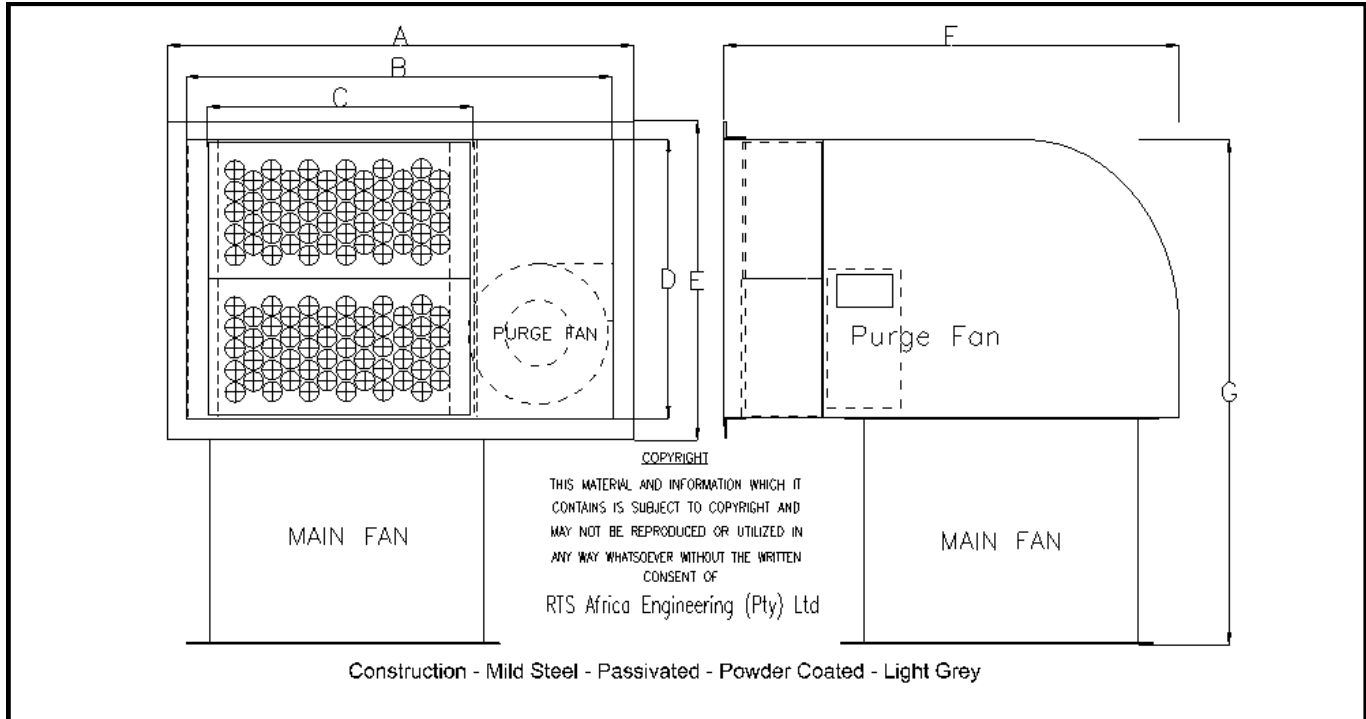

MODEL	A	B	C	D	E	F	G	WALL CUT OUT SIZES mm				MASS
SPIN0002V	810	730	475	305	385	710	700	H	305	W	475	78kg
SPIN0005V	810	730	475	495	575	830	890	H	495	W	475	118kg
SPIN0007V	822	738	750	730	810	950	1140	H	480	W	735	182kg
SPIN0008V	1065	985	1000	730	810	950	1140	H	480	W	980	OA
	SPIN0002		SPIN0005		SPIN0007		SPIN0008					
Spin Module	RTS/0002		RTS/0002		RTS/0002		RTS/0002					
RTS SPIN Modules	1		2		3		4					
Air Flow - Nm ³ /hr	1500 - 2200		3000 - 5000		5500 - 8000		7000—9500					
Room Pressurisation	100Pa		100Pa		100Pa		100Pa					
Main Fan - Type	Dynamic—Axial		Dynamic—Axial		Dynamic—Axial		Dynamic—Axial					
Dia	400mm		500mm		560mm		560mm					
Volts	400/525		400/525		400/525		400/525					
Phase	3		3		3		3					
kW	0.75		3.0		4.0		5.5					
FLC	1.81A		4.58A		7.81A		8.1A					
Poles	2		2		2		2					
rpm	2880		2880		2880		2880					
Purge Fan - Type	EBM 160		EBM 180		EBM 180		EBM D2E160AB0106					
Dia	226mm		281mm		281mm		241					
Volts	230		230		230		230					
Watts	240		347		347		410					
Phase	1		1		1		1					
FLC	1.1A		1.65		1.65		1.8					
rpm	2100		2580		2580		1850					



RTS Africa Engineering

Phone: +27(0) 12 433 6335
Cell: +27(0) 82 895 4507

Web: www.rtsafrica.co.za
Email: Info@rtsafrica.co.za

(Pty) Ltd

Co. Reg. 2015/038861/07

HORIZONTAL SPIN FILTER ASSEMBLIES

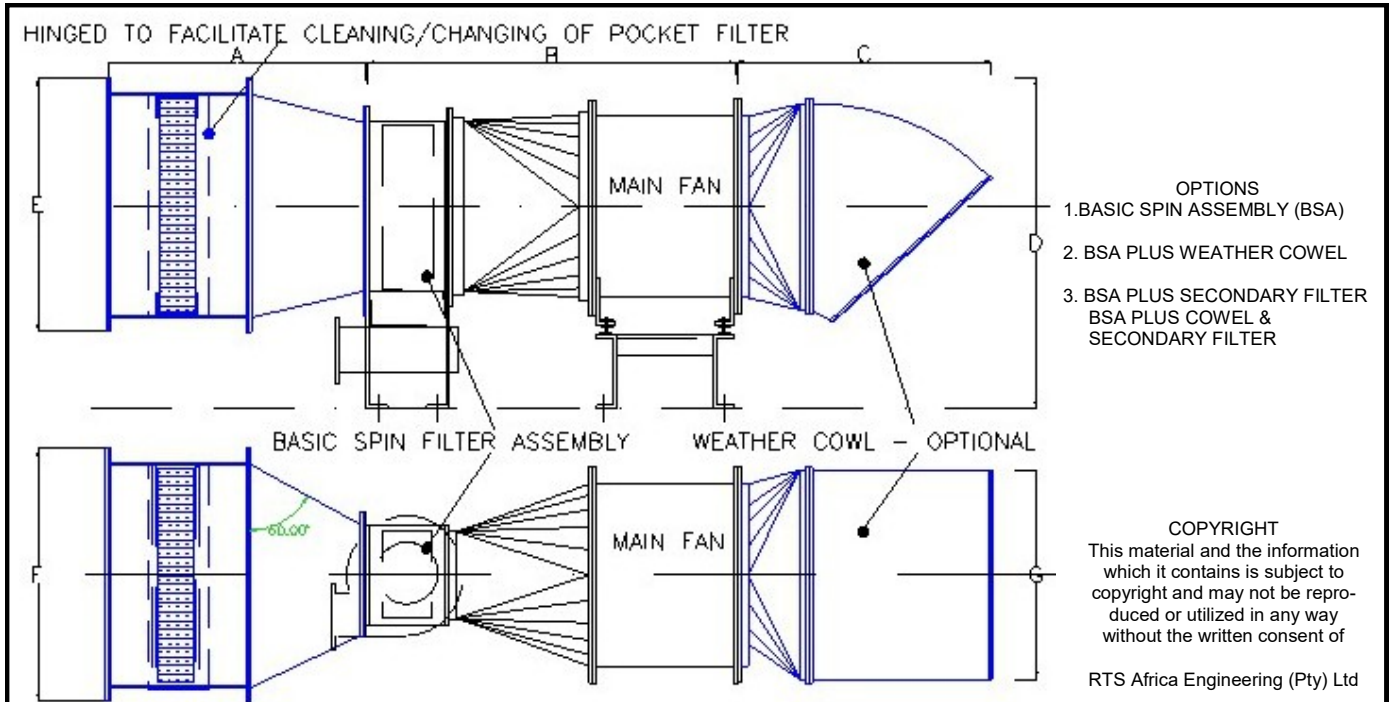

UNIT	A	B	C	D	E	F	G	FLANGE	MASS
SPIN0002H(C)F0	715	1002	568	782	610	610	485	40	OA
SPIN0005H(C)F0	715	1030	850	973	610	1220	860	40	OA
SPIN0007H(C)F0	715	1030	1100	1060	1220	1220	1000	40	OA
SPIN0008H(C)F0	715	1030	1200	1060	1220	1220	1000	40	OA
	SPIN0002H(C)F0		SPIN0005H(C)F0		SPIN0007H(C)F0		SPIN0008H(C)F0		
Spin Module	RTS/0002		RTS/0002		RTS/0002		RTS/0002		
Modules #	1		2		3		4		
Air Flow - Nm ³ /hr	1800 - 2400		3500 - 5000		5000 - 7000		7000 - 9000		
Room Pressurisation	100Pa		100Pa		100Pa		100Pa		
Main Fan - Type	Dynamic—Axial		Dynamic—Axial		Dynamic—Axial		Dynamic—Axial		
Dia	500mm		500mm		560mm		560mm		
Volts	400/525		400/525		400/525		400/525		
Phase	3		3		3		3		
kW (Absorbed)	1.62		1.62		3.81		4.76		
FLC	4.58A		4.58A		7.81A		8.20A		
Poles	2		2		2		2		
rpm	2880		2880		2880		2880		
Purge Fan - Type	EBM 160—Centrifugal		EBM 180—Centrifugal		EBM 180—Centrifugal		EBM 160—Centrifugal		
Dia	226mm		281mm		281mm		241mm		
Volts	230		230		230		230		
Watts	240		347		347		410		
Phase	1		1		1		1		
FLC	1.1A		1.65		1.65		1.8		
Rpm	2100		2580		2580		1850		